

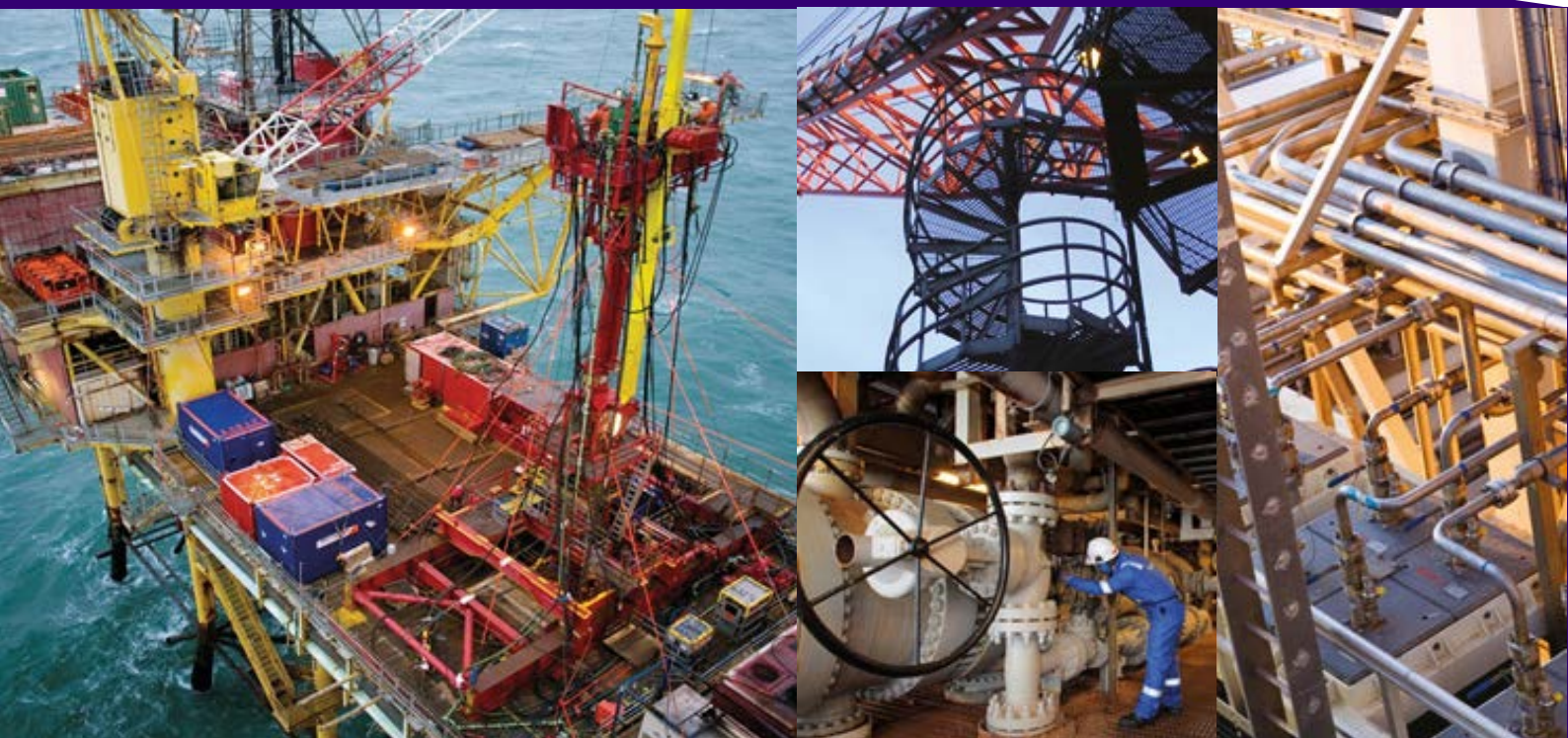

Oil & Gas
Authority



OIL&GASUK



Code of Practice on Access to Upstream Oil and Gas Infrastructure on the UK Continental Shelf

August 2017

Acknowledgments

In preparing and publishing this document, Oil & Gas UK gratefully acknowledges the contribution of the Commercial Managers Forum ICOP work group.

While every effort has been made to ensure the accuracy of the information contained in this publication, neither Oil & Gas UK, nor any of its members will assume liability for any use made of this publication or the model agreement to which it relates.

Any material within this code that has been sourced from others has been reproduced with the permission of its owners. Contains public sector information licensed under the Open Government Licence v3.0, which can be found at –

www.nationalarchives.gov.uk/doc/open-government-licence/version/3/

The information contained herein is given for guidance only. This code is not intended to replace professional advice and is not deemed to be exhaustive or prescriptive in nature. Although the authors have used all reasonable endeavours to ensure the accuracy of this code neither Oil & Gas UK nor any of its members assume liability for any use made thereof. In addition, this code has been prepared on the basis of practice within the UKCS and is not designed for use in other jurisdictions. All rights reserved. No part of this publication may be reproduced, stored in a retrieval system, or transmitted in any form or by any means, electronic, mechanical, photocopying, recording or otherwise, without prior written permission of the publishers.

Crown copyright material is reproduced with the permission of the Controller of Her Majesty's Stationery Office.

Copyright © 2017 The UK Oil and Gas Industry Association Limited trading as Oil & Gas UK

ISBN: 1 903 004 84 5

PUBLISHED BY OIL & GAS UK

London Office:

6th Floor East, Portland House, Bressenden Place, London, SW1E 5BH

Tel: 020 7802 2400 Fax: 020 7802 2401

Aberdeen Office:

Exchange 2, 3rd Floor, 62 Market Street, Aberdeen, AB11 5PJ

Tel: 01224 577250 Fax: 01224 577251

info@oilandgasuk.co.uk

www.oilandgasuk.co.uk

Contents

1	Introduction	5
2	Legal Framework	6
3	The Commercial Code of Practice	8
4	Scope of this Code	9
5	Principles of this Code	10
5.1	Overarching Principles	10
5.2	Specific Principles	10
6	Flowcharts of Best Practice for Negotiations	11
7	Provision of Information	13
7.1	General	13
7.2	High Level Capacity Information (Publicly Available)	13
7.3	Specific Information For Prospective Users	13
7.4	Information Exchange Between Bona Fide Enquirers and Infrastructure Owners	14
8	Timeliness	15
9	Procedure For Late-stage Negotiations	16
9.1	Referral to the OGA	16
9.2	OGA Acting on Own Initiative	17
10	Minimising Conflicts of Interest	18
11	Provision of Non-Discriminatory Negotiated Access	19
12	Separation of Services (Unbundling)	20
13	Fair and Reasonable Tariffs and Terms	21
13.1	General	21
13.2	Liabilities and Indemnities	21
13.2.1	Introduction	21
13.2.2	Tie-in Phase	22
13.2.3	Transportation and Processing Phase	22
14	Publication of Key Commercial Terms	23
15	Maintenance of the Code	24
	Appendices	3
A	Legislative Background	3
B	Summary of the UK Continental Shelf Oil and Gas Industry Commercial Code of Practice	5
C	Definitions and Explanations	6
D	Publicly Available Information for Prospective Users: High Level Capacity Information and Infrastructure-specific Information	10
E	Automatic Referral Notice Pro-Forma	12
F	Pro-Formas for Publication of Agreed Terms and Conditions and Worked Examples for a Fictitious Development	14

List of Abbreviations

Abbreviations	Definitions
API	American Petroleum Institute
ARN	Automatic Referral Notice
BERR	Department for Business, Enterprise and Regulatory Reform
CA	Confidentiality Agreement
CCOP	Commercial Code of Practice
CDA	Common Data Access
CMA	Competition and Markets Authority
CMF	Commercial Managers Forum
CULA	Cross User Liability Agreement
CTA	Construction and Tie-in Agreement
DECC	Department of Energy and Climate Change
DTI	Department of Trade and Industry
EC	European Commission
EU	European Union
GN	ICOP Guidance Notes
HSE	Health and Safety Executive
ICOP / Code	Code of Practice on Access to Upstream Oil and Gas Infrastructure on the UK Continental Shelf (or Infrastructure Code of Practice)
JV	Joint Venture
L&I	Liabilities and Indemnities
LNG	Liquefied Natural Gas
MER UK	Maximising Economic Recovery of UK Petroleum
NGLs	Natural Gas Liquids
NTS	National Transmission System
OFT	Office of Fair Trading
OGA	Oil and Gas Authority
Oil & Gas UK	The UK Offshore Oil and Gas Industry Association Limited trading as Oil & Gas UK
OIM	Offshore Installation Manager
SOR	Statement of Requirement
SoS	Secretary of State
TPA	Transportation and Processing Agreement
TPOSA	Transportation, Processing and Operating Services Agreement
UKCS	United Kingdom Continental Shelf

1 Introduction

- (1) This non-statutory Code of Practice on Access to Upstream Oil and Gas Infrastructure on the UK Continental Shelf (also known as the “Infrastructure Code of Practice” and abbreviated here as the “Code” or “ICOP”) sets out principles and procedures to guide all those involved in negotiating third-party access to oil and gas infrastructure on the UK Continental Shelf (UKCS).
- (2) Its purpose is to facilitate the utilisation of infrastructure for the development of remaining UKCS reserves through timely agreements for access on fair and reasonable terms, where risks taken are reflected by rewards.
- (3) By their endorsement of this Code, parties make a commitment to be guided by its principles and procedures. Parties to this Code also commit to take part in the periodic reviews of its effectiveness.
- (4) This Code was developed by Oil & Gas UK in consultation with a wide range of parties including the relevant regulator – currently the Oil and Gas Authority (OGA) but previously Government Departments DTI, BERR and DECC. It became effective in August 2004 and superseded the earlier Offshore Infrastructure Code of Practice dating from 1996. It was revised in 2012 and 2017 to reflect changes to legislation and to make general improvements.
- (5) Guidance to this Code has also been developed by Oil & Gas UK through a broad industry working group. This guidance became separately available from August 2008 with the latest update being in 2017.

2 Legal Framework

- (1) The Energy Act 2011 gives the OGA powers to settle disputes relating to access to infrastructure by determining that access be provided and on what terms. These powers are summarised in Annex A.
- (2) The OGA has issued guidance on the way it anticipates those powers would be used (refer to OGA Guidance on Disputes over Third Party Access to Upstream Oil and Gas Infrastructure¹). The OGA guidance, which may be updated from time to time, includes references to the relevant legislation and also includes a discussion of relevant UK and EU competition law.
- (3) In offering and considering terms of access, particularly the basis on which tariff levels are set, negotiating parties should have regard to the principles by which the OGA has indicated it would be guided, should they not reach agreement and the prospective user were to seek a determination from the OGA. The terms that would be determined by the OGA are expected to be in line with those that would be offered where there is effective competition.
- (4) The requirement to maximise the economic recovery of offshore UK petroleum was introduced into UK law in 2015. This 'principal objective' applies to relevant persons including holders of petroleum licences and owners of upstream petroleum infrastructure. The OGA is required to produce one or more strategies (and periodically review them) for enabling the principal objective to be met. Relevant persons and the OGA are required to comply with the current strategy or strategies. The OGA's 2016 strategy² is 'The Maximising Economic Recovery Strategy for the UK', also known as the 'MER UK Strategy'.
- (5) The MER UK Strategy expects that terms for access to infrastructure will be fair and reasonable, and will be agreed in a timely manner. The outcome from infrastructure access negotiations may also contribute to any hub strategies (as described in OGA Stewardship expectations) or wider area/regional plans developed in support of the MER UK Strategy.
- (6) In relation to infrastructure, the application of competition law is an evolving area and the requirements of this Code may need to be updated accordingly. Advice was received from the Office of Fair Trading (OFT, the UK competition law regulator at the time) when this Code was originally drafted in 2004. The advice indicated that the Code did not appear to raise any competition concerns and appeared likely to meet its objective of increasing the usage of spare capacity, but the onus was on industry to ensure that implementation of the Code complies with competition laws. No significant issues have

¹ See the OGA's Guidance on Disputes over Third Party Access to Upstream Oil and Gas Infrastructure at www.ogauthority.co.uk/media/2711/oga_dispute_resolutions-guidance.pdf

² See the OGA's MER UK Strategy 2016 at www.ogauthority.co.uk/news-publications/publications/2016/maximising-economic-recovery-of-uk-petroleum-the-mer-uk-strategy/

been raised in connection with competition law since the Code was introduced, and so the original advice is still considered to be relevant. More recently, the OFT's successor, the Competition and Markets Authority (CMA) has commented, more generally, that it is 'important to guard against the risk that unwarranted caution about the potential application of competition law chills beneficial collaboration, and the OGA reiterated the general position that EU and UK competition law are based on the principles of self-assessment, where the onus of determining if a particular activity is compliant with competition law rests with the individual businesses concerned'^{3,4}.

³ See CMA letter to Amber Rudd dated 3 December 2015

www.gov.uk/government/uploads/system/uploads/attachment_data/file/482374/CMA_letter_to_the_Rt_Hon_Amber_Rudd_MP_-_Energy_Bill_competition_issues.pdf

⁴ See Amber Rudd response to CMA dated 1 March 2016

www.gov.uk/government/uploads/system/uploads/attachment_data/file/506332/20160301_-_S_of_S_Letter_to_Alex_Chisholm_-_CMA_-_1_March_2016.pdf

3 The Commercial Code of Practice

- (1) This Code sets out specific principles and procedures designed to govern access to infrastructure. It is complementary to the oil and gas industry's overarching Commercial Code of Practice (CCOP), first agreed in 2002 and revised in 2016, within which commercial negotiations should be conducted to promote co-operative value generation. A summary of the CCOP is included as Annex B.

4 Scope of this Code

- (1) This Code applies to the processing and conveyance of all UK oil and gas throughout the hydrocarbon production and supply chain from wellhead through to receiving terminals and initial onshore processing facilities. As well as infrastructure on the UKCS and within territorial waters, this includes onshore oil and gas terminals and pipelines which handle (a) oil up to the point at which it has been stabilised (i.e. to the point at which the seller in a sale at arm's length could reasonably make delivery) and (b) gas prior to its introduction into the National Transmission System (NTS) (or other pipeline distribution system operated by a gas transporter) or its introduction into a downstream interconnector. This Code applies to the conveyance of fuel gas. This Code does not apply to access to the NTS, interconnectors and LNG import terminals.
- (2) This Code applies to:
 - All parties negotiating new contracts for access to such infrastructure and the provision of infrastructure services by infrastructure owners.
 - Infrastructure owners who may be approached from time to time by prospective users requesting information pertaining to such infrastructure.
 - Prospective users requesting such information.
 - All parties who have capacity rights in infrastructure systems but do not own the physical infrastructure.
- (3) This Code applies only to those hydrocarbon volumes not already covered by existing contractual arrangements.
- (4) Annex C provides a fuller definition of infrastructure owner and other terms having specific meaning in this Code.
- (5) Access to infrastructure systems through this Code should not be in conflict with good operating practices, the safety and integrity of the system or give rise to unacceptable environmental impacts. It is the duty of all parties to comply with any relevant legislation in respect of health, safety and the environment.

5 Principles of this Code

5.1 Overarching Principles

- Parties uphold infrastructure safety and integrity and protect the environment.
- Parties follow the Commercial Code of Practice and Negotiations Best Practice. The key principles of the CCOP are below (as summarised in Annex B):
 - Comply with the MER UK Strategy,
 - Being efficient and positive in negotiations,
 - Reviewing and improving performance.

5.2 Specific Principles

- Parties provide meaningful information to each other prior to and during commercial negotiations.
- Parties support negotiated access in a timely manner.
- Parties undertake to submit an automatic referral notice (ARN) to the OGA.
- Parties resolve conflicts of interest.
- Infrastructure owners provide transparent and non-discriminatory access.
- Infrastructure owners provide tariffs and terms for unbundled services, where requested and practicable.
- Parties seek to agree fair and reasonable tariffs and terms, where risks taken are reflected by rewards.
- Parties publish key, agreed commercial provisions.

6 Flowcharts of Best Practice for Negotiations

FLOW CHART 1: PREPARATION, INITIATION AND EARLY NEGOTIATION

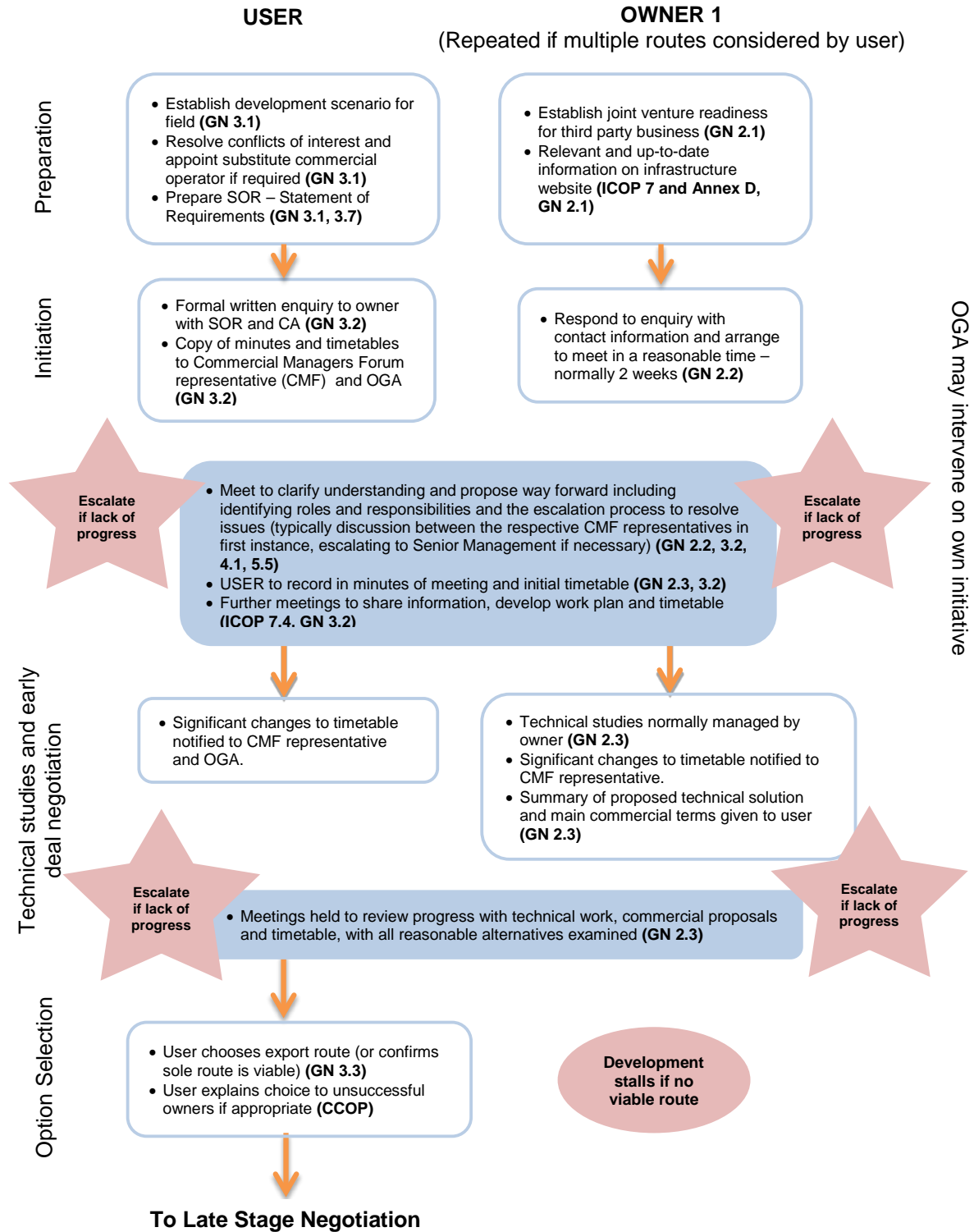

GN = Refer to the ICOP Guidance Notes

FLOW CHART 2: LATE STAGE NEGOTIATION AND CONCLUSION

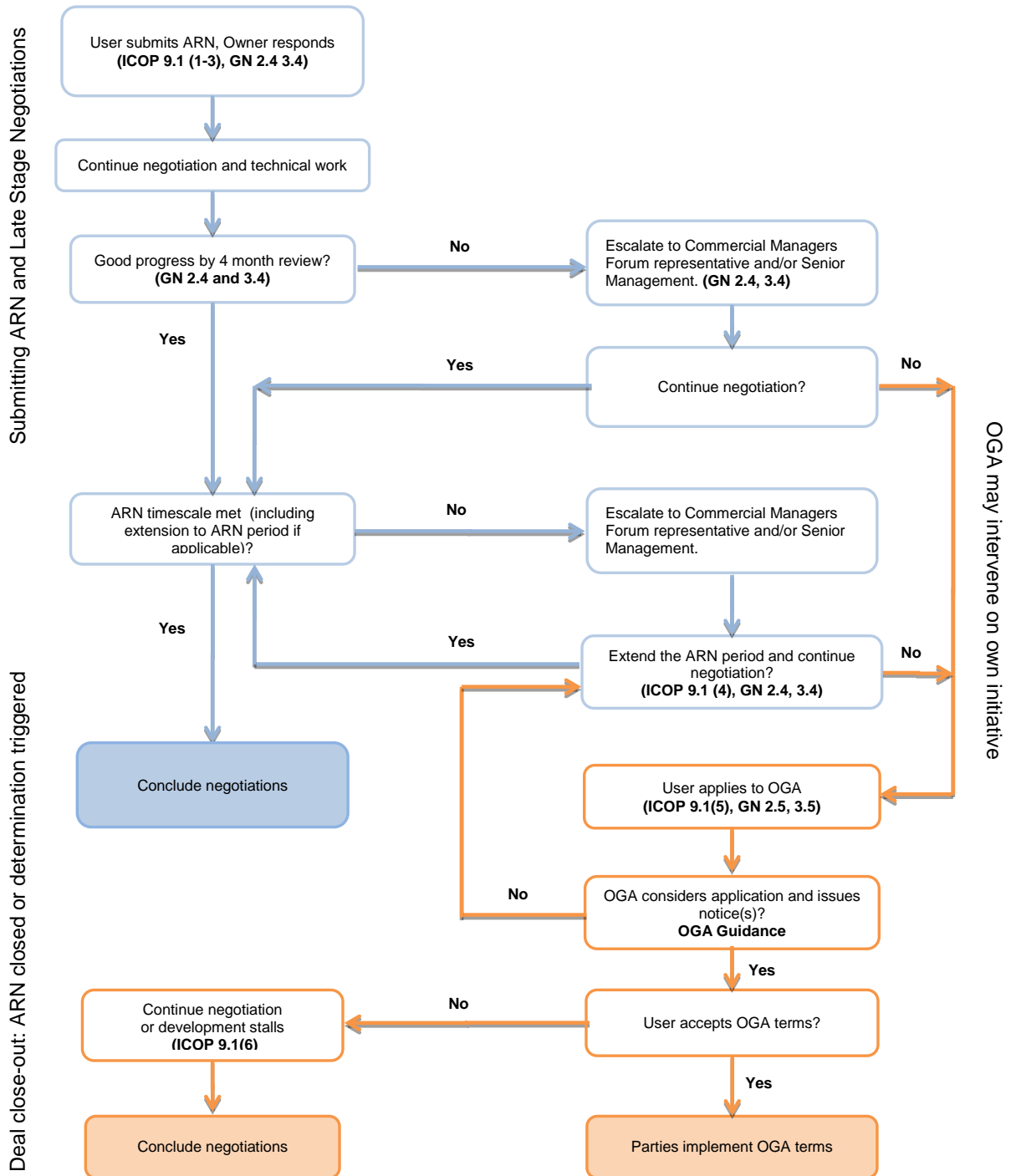

7 Provision of Information

7.1 General

- (1) Infrastructure owners should examine, maintain and review data delivery mechanisms so that prospective users can obtain an informed view of infrastructure options in their areas of interest. In particular, prospective users should have ready access to current operational and ullage data sufficient to enable the prospective user to undertake basic economic screening of alternative offtake options. Prospective users or agents acting on their behalf may be required to register for access to such data.
- (2) The cost of maintaining such information should be borne by the infrastructure owners and should be made available without charge, in good faith, on a no-liability basis.
- (3) Infrastructure owners shall be responsible for providing and maintaining the information for their facilities. The data collation and presentation may be carried out by the infrastructure operator on behalf of all infrastructure owners.
- (4) Owners of infrastructure which may be utilised for third-party access should provide information within the framework outlined below.

7.2 High Level Capacity Information (Publicly Available)

- (1) High level infrastructure capacity information should be made publicly available via the internet, by means of a company website that can be found using search engines and may also be inter-linked with a centralised website, the UK Oil and Gas Data portal . UK Oil and Gas Data is a database with public access, managed by Common Data Access Ltd which is a subsidiary of Oil & Gas UK. Annex D Paragraph 1 presents an example in the format of a 'traffic lights' model. Alternative formats (graphical, tabular) are acceptable.

7.3 Specific Information for Prospective Users

- (1) Specific information should be made available to provide a readily accessible means to find out more about the infrastructure system's capacity and other relevant technical data, for the purpose of determining the suitability of the infrastructure to meet a prospective users' transportation and processing requirements.
- (2) Information should normally be available directly via a website but, as a minimum, it should be made available on request within a reasonable time period (e.g. within 14 days of an enquiry). The format of any information will be at the discretion of the owner/operator.
- (3) The owner/operator is not obliged to undertake material incremental study activities in order to be in a position to provide the data requested.
- (4) Annex D Paragraph 2 sets out the minimum data requirements for infrastructure-specific information which is to be made publicly available.

7.4 Information Exchange Between Bona Fide Enquirers and Infrastructure Owners

- (1) Where prospective users wish to investigate developing their discovered hydrocarbons, they need to enter into more substantive discussions with infrastructure owners/operators. This Code refers to such applicants as bona fide enquirers. To facilitate such discussions, bona fide enquirers should provide information such as, but not limited to:
 - Name of the field/licence/location and owners/operator
 - Broad outline of the development, the commercial process and the proposed start-up date
 - Outline of services requested, including: production profiles/capacities required, compositions and hydrocarbon specification (e.g. H₂S and CO₂ content, specific gravity etc)
 - Other related services requested from other infrastructure owners.
- (2) Following receipt of this request from a bona fide enquirer, infrastructure owners/operators should provide such additional information as may be appropriate to successfully conclude a commercial agreement.
- (3) Parties' data should be provided in good faith, be relevant and meaningful and, although it may change during the course of negotiations, they should recognise the time and cost involved in taking account of such changes.
- (4) The accuracy and completeness of data provided under items (1) to (3) above shall be on a no-liability basis. However, liability may be covered in the final commercial agreements.

8 Timeliness

- (1) Negotiations should be completed as quickly as possible within the constraints of both parties seeking a fair, reasonable and technically sound outcome and of prudent corporate governance procedures. When a party believes that it will need to give consideration to competition law matters in connection with infrastructure access, having reviewed carefully the extent to which such consideration is necessary (see paragraph 2(6)), it is expected that this will be done in a timely manner and ideally prior to the commencement of any negotiations.
- (2) To facilitate timely progress, standard terms and conditions for systems should be developed, as far as reasonably practicable, as a starting point. This is seen as particularly valuable for assisting the provision of streamlined offers for small fields.
- (3) Best practice for the negotiating process is shown diagrammatically in the flowcharts in Section 6. The timings indicated are maxima; if negotiations can proceed more quickly, then this should be the aim of both parties.
- (4) To provide a framework for negotiations, at the commencement of negotiations both parties should agree a timetable identifying insofar as possible the technical, operational, legal and commercial issues that require resolution and agreement prior to completion of the negotiation and execution of the appropriate commercial arrangements. The bona fide enquirer should indicate in this timetable the point at which he will submit the automatic referral notice (Annex E). This point should not be more than 6 months prior to the target date for completion of negotiations.
- (5) Neither party should seek to introduce delay into negotiations for the purpose of gaining commercial advantage. Equally, it is not acceptable that pursuing a rapid conclusion to negotiations should be used as a strategy to extract commercial advantage in circumstances where there are legitimate issues that require further research, investigation, resolution or negotiation.

9 Procedure for Late-Stage Negotiations

9.1 Referral to the OGA

- (1) Bona fide enquirers should make an undertaking that they will apply to the OGA to secure access using the powers under the Energy Act 2011 if they are not able to reach agreement in due course with the infrastructure owner. This practice, by use of an Automatic Referral Notice (ARN), has been found to be helpful in encouraging structure and timeliness in late-stage negotiations and should not be seen as an aggressive move. The way in which the undertaking should be made and managed is described below.
- (2) The appropriate time to submit the ARN should be determined by the bona fide enquirer – when they have chosen their export route and have sufficient technical, cost and economic understanding to have reasonable confidence in completing the negotiation within a set period. The default set period is 6 months, but this can be adjusted to suit the specific circumstances. Where there are concurrent negotiations being carried out for different sections of the export route, for example because they are in different ownership, a separate ARN should be raised for each.
- (3) To raise an ARN, the bona fide enquirer should complete Part 1 of the pro-forma in Annex E and send it to the infrastructure owner/operator, copied to the OGA. The infrastructure owner/operator should complete Part 2 of the pro-forma and return it to the bona fide enquirer with a copy to the OGA in a timely manner. Ideally the infrastructure owner/operator should be supportive of the proposed timescale for the negotiation, but Part 2 allows any concerns to be raised if necessary about completing the negotiation within the set period.
- (4) If it becomes evident later that an extension to the set period will be required to facilitate a satisfactory agreement, the bona fide enquirer should inform the OGA. Such a notification must propose a revised period and should normally be made with the knowledge of the infrastructure owner/operator.
- (5) If negotiation fails to reach a satisfactory conclusion within the set period (revised as appropriate) and access is still required, the bona fide enquirer should apply to the OGA for a notice under the Energy Act 2011 to secure access to the infrastructure in question. The process for making an application is described in the OGA Guidance on Disputes over Third Party Access to Upstream Oil and Gas Infrastructure referenced in section 2. A failure to make an application after the set period is reached without clear reasons being given may lead to the OGA invoking the process described in section 9.2 below.
- (6) If access to the infrastructure is no longer required at any time after raising an ARN, the bona fide enquirer should notify the owner/operator in writing, copied to the OGA. The undertaking in the ARN will then cease.

9.2 OGA Acting on Own Initiative

- (1) Where the OGA believes that the parties in a negotiation have had a reasonable time in which to reach agreement and that there is no realistic prospect of them so doing, it may decide to issue a notice on its own initiative to secure access to the prospective user. This can take place independently of the process described in section 9.1 above.

10 Minimising Conflicts of Interest

- (1) Where a party could be a negotiator both in its capacity as an infrastructure owner and as a bona fide enquirer, it will normally be expected to elect at the outset to be a negotiator in only one of these capacities.
- (2) Similarly, where a party has ownership interests in more than one infrastructure system which are likely to be competing to provide similar services to a bona fide enquirer, it will normally be expected to elect at the outset to be a negotiator in, at most, one of the competing systems.
- (3) In the event that a party elects not to be a negotiator, the other parties shall recognise that such election does not comprise a waiver of any rights which it may have in relation to its approval of the proposed agreement.
- (4) A party that elects to step out of negotiations shall, in accordance with good commercial practice in the UKCS, be entitled to:
 - Receive and comment on those mainly operational, technical and HSE related issues that it reasonably considers may be detrimental to the infrastructure owners' position and/or to their ability to comply with their fiduciary, contractual and legal obligations
 - Exercise its rights as an infrastructure owner in relation to the approval of the terms of the proposed agreement.

11 Provision of Non-Discriminatory Negotiated Access

- (1) Infrastructure owners should consider all bona fide requests for services and negotiate and offer terms to third parties in good faith, without favour to any particular company or group of companies. This principle of transparent and non-discriminatory negotiated access applies to all infrastructure coming within the scope of this Code.
- (2) Discrimination by an infrastructure owner includes the application by them of dissimilar conditions to equivalent transactions. This does not mean that infrastructure owners need to set fixed common prices for particular services, since different terms and conditions may be applied where there are differences in the service provided or the cost or risk of supply.
- (3) While infrastructure owners should not, by virtue of their ownership, discriminate by giving special preference to particular companies or agents, they may make reasonable provision of capacity for their own use (refer to Annex C (6)), but overall should look to prioritise access which maximises the value of economically recoverable petroleum.
- (4) Where bona fide enquirers are competing for access to the same limited services, the infrastructure owners are free to make a choice as long as the decision is in accordance with the principles and purpose of this Code.
- (5) Infrastructure systems should operate on the principle of clearly specified priorities which are known to all users of the system. However, it is recognised that existing contracts or capacity constraints may mean that a new user cannot be granted equal priority to existing users of the facilities.

12 Separation of Services (Unbundling)

- (1) Where it is practical and requested, infrastructure owners should offer terms for services on an unbundled basis. This should allow infrastructure owners to offer competing terms and services for distinctly separate components. Separation may also be appropriate where, although there is only one discrete chain of service, the parts of the chain have different ownership.
- (2) Infrastructure owners should discuss any technical obstacles to unbundling with prospective users with a view to finding solutions that enable separation.
- (3) When comparing an unbundled service offer with a 'one stop shop' integrated offer, a number of factors need to be considered by the parties, including scale, risk/reward sharing, and the impact on the overall system e.g. sterilising capacity. Terms for services offered should not result from an infrastructure owner leveraging market power in one component to deny choice in other parts of the chain.

13 Fair and Reasonable Tariffs and Terms

13.1 General

- (1) Tariffs and terms offered and agreed between parties should be fair and reasonable, where risks taken are reflected by rewards. This can best be secured by open competition between different infrastructure systems to meet prospective users' requirements, and this should be encouraged wherever possible.
- (2) As well as being entitled to make a reasonable provision of capacity for their own use and the need to honour their existing contractual commitments, in offering terms to bona fide enquirers, infrastructure owners may take into account any realistic impact of prospective new business on their system.
- (3) Where capacity is not available within existing infrastructure and the owner does not wish directly to incur the additional investment costs involved in providing additional capacity, the infrastructure owner is expected to provide the incremental capacity but it is the responsibility of the bona fide enquirer to fund such investment, including compensation for those costs and exposures agreed by the parties, in line with normal industry practice.
- (4) Companies should use industry standard forms and precedents wherever practical as a basis to reduce complexity.

13.2 Liabilities and Indemnities

13.2.1 Introduction

- (1) The liability and indemnity regime forms an important part of the overall risk-reward balance with consequent impact on reward levels. The parties should bear appropriate risks having regard for the respective rewards expected to be enjoyed by each. In this context, the capacity of bona fide enquirers investing in smaller fields to bear risk may be more limited than for those investing in larger fields.
- (2) Parties should address liabilities and indemnities early in a negotiation process. Generally, this should be prior to the submission of an ARN.
- (3) In order to promote the development of remaining UKCS reserves, parties will endeavour to follow this Code but at the same time recognise that the terms which infrastructure owners can offer may be influenced by terms prevailing with existing users and by the specific circumstances of each proposal.
- (4) Generally, a party should accept a duty to mitigate its losses when seeking recovery from another party.

13.2.2 Tie-in Phase

- (1) If the parties agree that, taking into account factors such as the level of future tariffs and the potential exposures of the infrastructure owners, the bona fide enquirers should indemnify the owners against liabilities and losses arising out of tie-in or modification activity, then owners should generally be prepared to offer caps on their maximum liability exposure. These caps should be reasonable and have regard to the realistic exposure of the owners and the risk-reward balance of the overall transaction. In the case of planned shut-downs required for the sole purposes of the tie-in or modification, the parties are encouraged to quantify and pre-agree a reasonable level of liquidated damages to cover losses arising from deferral of production. These may be calculated on an hourly or daily basis and subject to a reasonable cap.
- (2) Parties should be as specific as possible as to the types and categories of non-physical loss recoverable under any indemnity with a view to avoiding subsequent disputes on the extent of recovery under the indemnity and helping the placement of any insurance sought for the risk. In some cases, it may be appropriate for the parties to agree that specific insurance arrangements should be put in place to cover tie-in or modification activity.

13.2.3 Transportation and Processing Phase

- (1) During the production period, post completion of the tie-in phase, where appropriate, infrastructure owners and bona fide enquirers should normally adhere to the principle of 'mutual hold harmless' in relation to damage to property related to the activity, personal injury to their respective employees and their respective contractors' employees, pollution from their respective facilities and consequential losses, usually subject to exclusions for wilful misconduct. In addition, it is likely that there will need to be specific provisions addressing delivery of off-specification production and for the provision of any non-standard services. In many circumstances, bespoke liability and indemnity regimes have evolved in respect of certain infrastructure and these may fetter the discretion of the owners. Wherever possible, the general or standard terms and conditions relating to such regimes should be provided to bona fide enquirers on request.

14 Publication of Key Commercial Terms

- (1) Infrastructure owners should publish short summaries of newly concluded construction and tie-in agreements, transportation and processing agreements and/or operating services agreements within one month of these becoming unconditional. New users will provide an appropriate summary of the development to each owner, to accompany the information provided by the owner. In the case of access for new field developments, agreements would normally be expected to become unconditional at the time of the OGA granting development approval and, in any event, be no later than the date production commences.
- (2) This information should be posted on the infrastructure owner/operator's website or, if they do not have an appropriate website, on the UK Oil and Gas Data website.
- (3) The summary should follow the relevant pro formas in Annex F and thus identify all the principal or material commercial provisions of the agreement, including prices and a tariff range or ranges of sufficient accuracy to reflect the cost to the user of the services to be provided. Annex F also includes an example of the completion of pro formas for a fictitious development.
- (4) To provide an indication of terms and tariffs for further prospective users, summaries should remain on the website at least until the agreement terminates.

15 Maintenance of the Code

- (1) Oil & Gas UK with the support of the OGA, will be responsible for maintaining this Code. It will periodically review its effectiveness through consultation with its members, other UKCS licence holders and their representative bodies, terminal owners / operators and other interested parties, including the OGA and the CMA, to ensure that it remains relevant to the needs of users, prospective users and infrastructure owners.
- (2) Compliance with this Code, its effectiveness and whether it is fit for purpose will be reviewed at such times as may be determined by the OGA and the Oil & Gas UK Board, following consultation with interested parties.

(3) Contact points:

OIL & GAS UK

Upstream Policy Director
6th Floor East
Portland House
Bressenden Place
London
SW1E 5BH
020 78022400

OGA

Regulation Directorate
21 Bloomsbury Street
London
WC1B 3HF
0300 0201010

Appendices

A Legislative Background

Companies seeking access to infrastructure falling within the scope of the third-party access provisions of the Energy Act 2011 must apply in the first instance to the owners. If the parties are unable to agree satisfactory terms and conditions for access to that infrastructure, the prospective user may make an application to the OGA to resolve the dispute. In considering such applications, the OGA will take account of a number of factors specified in the legislation and will be under a duty to avoid prejudice to the owners and existing users. Should the OGA decide to set terms and conditions for access, it will issue one or more notices to the parties in order to bring this about. In specific circumstances, the OGA may decide to give a notice on its own initiative without having received an application from the user.

Prior to the Energy Act 2011 coming into force, third party access provisions existed in four Acts of Parliament. Sections 82 to 91 of the Energy Act 2011 replaced many of these provisions but also added new powers. Minor amendments to the Energy Act 2011 were made through sections 70-71 of the Energy Act 2016, and the powers to use the Energy Act 2011 were transferred from the Secretary of State to the OGA through Schedule 1 of the Energy Act 2016. The full text of both Acts can be obtained at:
www.legislation.gov.uk

A summary of the provisions is given below:

- A prospective user seeking access to an upstream petroleum pipeline, a relevant oil processing facility or a relevant gas processing facility, should apply to the owners of that infrastructure in the first instance.
- If the parties are unable to reach agreement on the terms and conditions, the prospective user may apply to the OGA for a notice that would secure rights of access.
- The OGA should consider whether the parties have had a reasonable time in which to reach agreement and will reject or adjourn the application if this test is not met.
- However, where the OGA believes that the parties in a negotiation have had a reasonable time in which to reach agreement and that there is no prospect of them doing so, it may decide on its own initiative to issue a notice to secure access to the prospective user. In this case the steps below are followed as if an application had been made. The OGA may require information to be provided by the owner or the prospective user in order to help decide whether to exercise this power.

- Should the OGA consider an application further, it has a right to demand relevant information – which may include financial information – which it has a general duty not to disclose to others. Failure to provide information to the OGA can be sanctioned under the provisions of Chapter 5 of Part 2 of the Energy Act 2016.
- In considering an application further, the OGA will take into account a number of factors specified in the Energy Act 2011 concerned with physical and technical constraints that apply to the infrastructure in question.
- Where the owners or an existing user is likely to be prejudiced by a notice, the OGA must specify appropriate payments by way of compensation in the notice.
- A notice may contain provisions to ensure that no person suffers a loss due to the mixing of different substances conveyed by the pipeline or processed by the facility.
- If it appears to the OGA that the pipeline or facility should be modified, then it may give a separate notice to the owner and prospective user to bring about those modifications.
- Anyone to whom a notice is given may apply to the OGA to vary a notice if it is considered that a variation is necessary to resolve a dispute in connection with the notice.
- The OGA may publish notices or variations, or a summary of their effect.
- Sections 89A and 89B of the Energy Act 2011, introduced in 2016, describe how rights and obligations transfer when there is a change of prospective user or infrastructure owner by way of assignment, assignation or transfer of ownership.

B Summary of the UK Continental Shelf Oil and Gas Industry Commercial Code of Practice⁵

As my company undertakes commercial activity relating to the UKCS, it will:

Comply with the MER UK Strategy

- Promote awareness of the MER UK Strategy among all relevant staff (including senior management and those located outside of the UK), external advisors and counterparties.
- Recognise that the “Central Obligation” of the Strategy requires that “relevant persons must, in the exercise of their relevant functions, take the steps necessary to secure that the maximum value of economically recoverable petroleum is recovered from the strata beneath relevant UK waters”.
- In support of that requirement consider whether collaboration or co-operation with other parties could reduce costs or increase recovery of economically recoverable petroleum and, where that is possible, communicate these benefits to other parties and, collectively, give consideration to commercial means of achieving those benefits.
- Analyse internally, and discuss with JV partners, external advisors, current and potential counterparties, the relevant commercial context, issues and opportunities associated with the situation, the MER UK Strategy and any relevant OGA MER UK Plans.

Be efficient and positive in negotiations

- Together with JV partners, external advisors and current and potential counterparties, establish and agree the issues that need to be addressed and a realistic Timetable to Completion (based on the key milestones in project maturation processes; asset transaction and completion processes, other concurrent activity and development plans).
- Use industry standard forms and precedents wherever practicable to reduce complexity, and contribute to the development of new standard solutions.
- Resource agreed activity appropriately in a manner which promotes positive engagement along with speedy and efficient resolution of all matters under negotiation.
- Empower staff and external advisors so that they can seek to resolve issues “in the room”. Where this is not possible, use company escalation quickly and decisively to prevent issues lingering.
- Report on progress regularly to the OGA, but only seek their involvement when asking them to opine on a company’s compliance with the Central Obligation or, where necessary and appropriate, to exercise their powers with respect to dispute resolution or third party access.

Review and improve

- Conduct a post activity review with counterparties to understand how the Code was complied with by all parties during the activity.
- Conduct an annual review of commercial activity to understand where opportunities to improve compliance lie.

⁵ See the Commercial Code of Practice and Negotiations Best Practice Guidelines at www.oilandgasuk.co.uk/ccop.cfm

C Definitions and Explanations

1. Affiliate

An affiliate is generally recognised to mean, in relation to a company, any holding company or subsidiary company of the company in question or any company which is a subsidiary company of any holding company of the company in question. The expressions 'holding company' and 'subsidiary' shall have the meanings ascribed to them in section 1159 of the Companies Act 2006, provided that a company shall be treated, for the purposes only of the membership requirement contained in subsections 1159(1)(b) and (c), as a member of another company even if its shares in that other company are registered in the name of (i) another person (or its nominee), whether by way of security or in connection with the taking of security, or (ii) its nominee. Given the corporate structure of some companies, such as Shell, the definition also includes such companies as is generally set out in commercial and other agreements between them and third parties in the UK.

2. Allocation, Attribution and Substitution

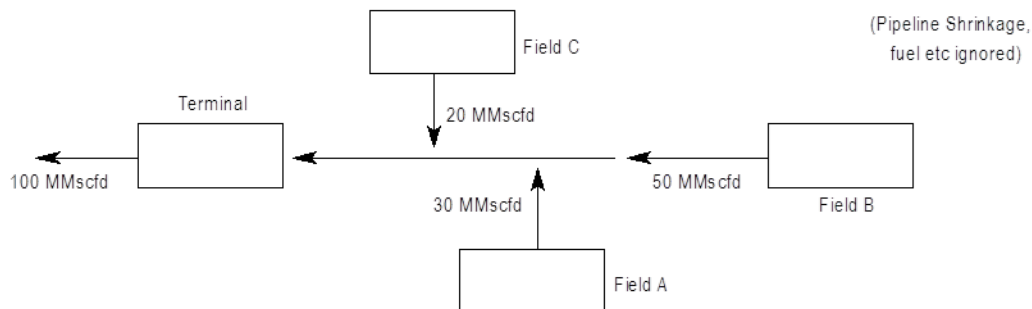

Allocation

The allocation process entails working out how much of the total volume of gas of a given energy value flowing out of a terminal and into the onshore transmission system has been input by individual fields feeding into that system. An example of such a process is given below:

Field	Allocated Volume
A	30
B	50
C	20
Total	100

Attribution

This takes account of the amounts substituted between fields as follows:

Field	Sales Nomination	Allocated Volume	Substitution	Attributed Volume
A	50	30	+20	50
B	30	50	-20	30
C	20	20	0	20

Substitution

This occurs when a field produces gas to satisfy the gas sales nomination of another field. In the above example this could be as follows:

Field	Sales Nomination	Allocated Volume	Substitution
A	50	30	+20
B	30	50	-20
C	20	20	0
Total	100	100	0

i.e. Field B is substituting 20 units to Field A.

Allocated volume approximates how much a field has produced. The **attributed** volume approximates how much a field has sold (which may all have been produced by that field or may include a volume of **substitution** from another field).

3. Categories of User

The provisions of information made available through this Code are to allow public access for all prospective users of the infrastructure systems to enable them to assess the options for prospective business in the UKCS.

Where prospective users are licensees with an established hydrocarbon resource and intend to negotiate access into an infrastructure system, they are referred to as bona fide enquirers. Some parts of this Code apply to information available to prospective users. Other parts apply to the information available to, and behaviours relevant to, the negotiations between bona fide enquirers and infrastructure owners/operators.

4. Capacity Terms

Firm: That capacity which is physically and contractually available upon request.

Interruptible: That capacity which can be made available, on a reasonable endeavours basis.

Ullage: That capacity of an offshore infrastructure system which is unallocated or uncontracted.

5. Infrastructure Owner

In the context of acquiring rights to use infrastructure, this means a party who owns or controls physical assets (pipelines or facilities) and/or a party with capacity rights capable of being sub-let (but who does not own the asset). Section 82(19) of the Energy Act 2011 gives the relevant definition, for the situation where the OGA is considering imposing terms. A narrower definition in the legislation applies to compulsory modification, being limited to a party who owns or controls infrastructure and so is in a position to make that modification. This is defined in section 84(10).

6. Reasonable Provision of Capacity

Owners of infrastructure are entitled to make reasonable provision of capacity for their own future use (including use by their affiliates). 'Reasonable' in this context is not capable of exhaustive definition and is therefore illustrated here by example.

It includes:

- Anticipated upsides or plateau extensions from fields currently using the infrastructure.
- New field developments where there is a firm plan or which are expected to be developed within a reasonable time frame (say 5 years) or which were foreseen and were part of the reason for the original decision to install the infrastructure.

Reasonable provision would, for example, not include deliberately refusing access in order to deny market access to a competitor or to gain some other market advantage. Nor is it reasonable for an infrastructure owner to refuse access on the basis that the owner will have a requirement for it in time for some as yet unidentified purpose.

7. Sterilising Capacity

Sterilising capacity to provide other services within the system (in addition to the capacity actually requested) as a result of accepting the particular request for service, prejudices the production of petroleum. This would include, for example:

- Where taking in a small field could reduce the ullage to the extent that a current negotiation with a large field could not be completed.
- Where a particular small field consumes all of the, say, de-propaniser capacity at an oil treating facility thus preventing the use of upstream capacity which would otherwise be available.
- Where a sour gas field would, by coming in, preclude the owners from a future opportunity to operate the system sweet.

8. Unbundling

Separating out services or activities in the hydrocarbon transportation/processing supply chain from reservoir to redelivery point that may be offered by more than one company so that each significantly distinct component can be separately identified, costed, priced, valued and provided.

D Publicly Available Information for Prospective Users: High Level Capacity Information and Infrastructure-specific Information

1. Publicly Available High-Level Capacity Information

As a minimum, and by way of an example, this basic capacity information could be equivalent to each infrastructure section being portrayed through consistent colour coded 'traffic lights' that reflect thresholds of availability over at least the next 5 years, as follows:

Indicative system capacity: (mbopd/mmscfd/'other')

'Traffic Light' Colour	Ullage as % of system capacity
Red	< 5%
Amber	5% to <25%
Green	> 25%

Notes:

- (1) If interruptible capacity can be made available over and above the firm capacity, the extent and timing availability of such interruptible capacity should be stated (e.g. for years 1 to 3, 100mmscfd interruptible capacity in summer, 20mmscfd in the winter).
- (2) A longer outlook on ullage should be provided in cases where red and amber traffic lights are shown for the next 5 years, so as to indicate when any capacity constraints are likely to recede.

2. Publicly Available Infrastructure Specific Information

The data should be to a sufficient level and time horizon to enable prospective users to determine whether or not the infrastructure has the potential to meet their transportation and processing requirements.

Infrastructure system capacities should be expressed in terms of the indicative system capacity and the ullage on a forward basis for each of points (5) through (12) in the following list:

- (1) Entry specification.
- (2) Exit specification.
- (3) Outline details of primary separation processing facilities.
- (4) Outline details of gas treatment facilities.
- (5) Oil export capacity.
- (6) Gas compression capacity.
- (7) Gas export capacity.
- (8) Gas lift capacity.
- (9) Produced water handling capacity.
- (10) Dehydration capacity.
- (11) H₂S removal capacity.
- (12) Water injection capacity.

Should further information or clarification on the above data be required by the prospective user to aid his evaluation of alternative offtake options, the prospective user is encouraged to enter into dialogue with the infrastructure owner/operator to discuss the specific nature of the further information necessary and specific to the prospective user's purposes at that time (e.g. availability of spare risers, details of 'mothballed' equipment which could be reused, details of key processing constraints etc).

Additional information that is needed by a prospective user for the purpose of screening the suitability of the system should not be unreasonably withheld if it is readily available to the owner/operator. This may include information relating to:

- uptime or operating efficiency,
- expected remaining life of the system, and
- the performance of the owner/operator in dealing with third party access requests.

Best practice for the owner/operator will be to include this and other relevant information that will assist prospective users on their website.

E Automatic Referral Notice Pro-Forma

In accordance with the industry Code of Practice on access to upstream oil and gas infrastructure on the UK Continental Shelf, the submission of this pro forma creates an undertaking by [UserOilCo] to apply for a notice from the Oil and Gas Authority (OGA) to secure access to the infrastructure in question if satisfactory negotiations for access have not been concluded within 6 months of the submission to [OwnerOilCo] (or such other date as may be agreed).

Part 1 To be completed by the field operator requesting services on behalf of bona fide enquirers and then sent to the infrastructure owner/operator and copied to the OGA.

Name of Field Operator	
Contact Details	
List all Field Owners (<i>bona fide enquirers</i>)	
Name of Field	
Licence No/Block	
Name of Infrastructure Owner/Operator to whom application is made	
Name of Host Infrastructure	
Outline of Services requested	
Identify any other related services needed from other infrastructure owners	

.....

Authorised Signature (for UserOilCo)

.....

Date

Part 2 To be completed by the infrastructure owner/operator receiving the request for services and then returned to bona fide enquirers and copied to the OGA.

Name of Infrastructure Owner/Operator	
Contact Details	
List all Infrastructure Owners	
Identify any key technical or commercial issues relating to the provision of the services requested including any that might prevent agreement being reached within 6 months	

.....

Authorised Signature (for OwnerOilCo)

.....

Date

F Pro-Formas for Publication of Agreed Terms and Conditions and Worked Examples for a Fictitious Development

	Page
Infrastructure Access Agreement Summary 1	3/4
Infrastructure Access Agreement Summary 2	5/6
Examples	
Construction and Tie-in	7/8
Transportation and Processing	9/10
Transportation, Processing and Operational Services	11/12
Field Agreement Suite Summary	13/14

F.1.1 Infrastructure Access Agreement Summary 1

This data is provided in accordance with the disclaimer conditions noted below:

<p>Provided in relation to the voluntary Industry Infrastructure Code of Practice. To be used in summarising construction and tie-in and transportation and processing agreements by the owner/operator for inclusion in the publication of key commercial terms (refer to Paragraph 13 (1)).</p>	<p>Ref:</p>
<p>Agreement Title and Date:</p>	

<p>Scope of Agreement/Responsibilities (refer to Note 1):</p>

<p>Key Provisions (refer to Note 2)</p>	
Commencement Date	
Entry Point	
Redelivery Point (s)	
Capacity/variation rights (Y/N) and timing (refer to Note 3)	
Send or Pay/carry forward provisions (Y/N)/Duration	
Priority rights during periods when service provision is reduced	
Technical Requirements (refer to Note 4)	
Payment Structure (refer to Note 5)	
Tariff range for service provided (refer to Note 6)	
Range of any separate contribution to capex and opex	
Any other payment(s) with range and timing (refer to Note 7)	
L&I/Risk Regime fundamentals	

<p>Important Additional Data (refer to Note 8)</p>

Notes

- (1) Include key provisions and services that have a material impact on risk-reward.
- (2) Include any important and unusual elements that materially impact risk-reward.
- (3) For each main stream e.g. oil, gas etc.
- (4) Should include relevant entry specifications and any important and unusual technical issues.
- (5) The ranges should reflect the type of service provided (price range should be within a 15% band).
- (6) Include summary of indexation principles with floors and ceilings.
- (7) Include any fee in kind type payments relating to single component streams, or production deferral in a CTA.
- (8) Include any key provisions that materially impact risk-reward not mentioned above (e.g. hydrocarbon accounting, risk, property, title, extension of terms, assignment (incl. limitations), security provisions, metering, termination, ownership and decommissioning in a CTA etc).

Disclaimer

The summary information provided above is provided by [] as the service provider:

- (1) In good faith and without any liability.
- (2) Without warranty, implied or express as to its accuracy or relevance of use by any other party.
- (3) Without obligation to provide any further information in respect of the agreement/transaction to which the summary information relates.
- (4) Without any obligation to provide access to infrastructure or services on the same terms and conditions.

F.1.2 Infrastructure Access Agreement Summary 2

This data is provided in accordance with the disclaimer conditions noted below:

Ref:	Provided in relation to the voluntary Industry Infrastructure Code of Practice. To be used in summarising construction and tie-in and transportation and processing agreements by the owner/operator for inclusion in the publication of key commercial terms (refer to Paragraph 13 (1)).
Infrastructure Access Summary for:	

Field Development:

Suite of Main Agreements (refer to Note 1)	
Ref:	Commercial Arrangement/Agreement title

Field Details:	
Field Name	
Licence	
Block Number	
Operator	
Partners	

Field Streams/Characteristics:					
Stream	Crude oil	Gas	Condensate	NGLs	Produced Water
Relevant (Y/N)					
Unique characteristics (refer to Note 2)					
Reserves					
Initial Rate					
Plateau					
Plateau/Peak production					

Notes

- (1) Other agreements may exist e.g. pipeline crossings, confidentiality, but they do not materially impact risk-reward.
- (2) For example – low API, high H2S, High CO2, significant sand production etc.

Disclaimer

The summary information provided above is provided by [] as the service provider:

- (1) In good faith and without any liability.
- (2) Without warranty, implied or express as to its accuracy or relevance of use by any other party.
- (3) Without obligation to provide any further information in respect of the agreement/transaction to which the summary information relates.
- (4) Without any obligation to provide access to infrastructure or services on the same terms and conditions.

F.1.3 Infrastructure Access Agreement Summary 1

This data is provided in accordance with the disclaimer conditions noted below:

Provided in relation to the voluntary Industry Infrastructure Code of Practice. To be used in summarising construction and tie-in and transportation and processing agreements by the owner/operator for inclusion in the publication of key commercial terms (refer to Paragraph 13 (1)).	Ref: CTA ISCCA 000001
--	--

Agreement Title and Date:

Agreement for the Construction and Tie-in of the Wine field to the Barrel platform dated 7th February 2004

Scope of agreement/responsibilities: (refer to Note 1)

*The Wine field Operator shall; drill the Wine field wells, install all the subsea equipment and flow lines and umbilical. [OwnerOilCo] as Barrel field Operator shall complete the tie in of the flowline to the spare Barrel platform riser including installation of a shutdown valve
[OwnerOilCo] as Barrel field Operator shall pull the Wine field umbilical up the spare tube
[OwnerOilCo] as Barrel field Operator shall install all necessary control, shutdown and metering systems on the platform and conduct all necessary commissioning tests*

Key Provisions (refer to Note 2)

Commencement Date	<i>Work to commence March 2005, completion by 1st October 2006</i>
Entry Point	<i>N/A</i>
Redelivery Point (s)	<i>N/A</i>
Capacity/variation rights (Y/N) and timing (refer to Note 3)	<i>N/A</i>
Send or Pay/carry forward provisions (yes/no)/Duration	<i>N/A</i>
Priority rights during periods when service provision is reduced	<i>N/A</i>
Technical Requirements (refer to Note 4)	
Payment Structure (refer to Note 5)	
Tariff range for service provided (refer to Note 6)	<i>N/A</i>
Range of any separate contribution to capex and opex	<i>Fixed price capex of £50 million, no production deferral anticipated</i>
Any other payment(s) with range and timing (refer to Note 7)	<i>None</i>
L&I/Risk Regime fundamentals	
Important Additional Data (refer to Note 8)	
<i>Additional equipment ownership and decommissioning liability will be for the Barrel platform owners.</i>	

Notes

- (1) Include key provisions and services that have a material impact on risk-reward.
- (2) Include any important and unusual elements that materially impact risk-reward.
- (3) For each main stream e.g. oil, gas etc.
- (4) Should include relevant entry specifications and any important and unusual technical issues.
- (5) The ranges should reflect the type of service provided (Price range should be within a 15% band).
- (6) Include summary of indexation principles with floors and ceilings.
- (7) Include any fee in kind type payments relating to single component streams, or production deferral in a CTA.
- (8) Include any key provisions that materially impact risk-reward not mentioned above (e.g. hydrocarbon accounting, risk, property, title, extension of terms, assignment (incl. limitations), security provisions, metering, termination, ownership and decommissioning in a CTA etc).

Disclaimer

The summary information provided above is provided by [OwnerOilCo] as the service provider:

- (1) In good faith and without any liability.
- (2) Without warranty, implied or express as to its accuracy or relevance of use by any other party.
- (3) Without obligation to provide any further information in respect of the agreement/transaction to which the summary information relates.
- (4) Without any obligation to provide access to infrastructure or services on the same terms and conditions.

F.1.4 Infrastructure Access Agreement Summary 1

This data is provided in accordance with the disclaimer conditions noted below:

<p>Provided in relation to the voluntary Industry Infrastructure Code of Practice. To be used in summarising construction and tie-in and transportation and processing agreements by the owner/operator for inclusion in the publication of key commercial terms (refer to Paragraph 13 (1)).</p>	<p>Ref: TPA ISCCA 000002</p>
<p>Agreement Title and Date: <i>Agreement for the transportation and processing of Wine field gas through SEGAL dated 7th February 2004</i></p>	

<p>Scope of agreement/responsibilities: (refer to Note 1) [OwnerOilCo] as SEGAL Operator shall provide the following main services (on behalf of owners): Transportation of Wine gas from the SEGAL entry point to St. Fergus Extraction and redelivery of sales spec gas into the NTS Extraction and transport of NGLs to Mossmorran Processing and redelivery of propane, butane, and condensate at Braefoot Bay jetties</p>

Key Provisions (refer to Note 2)	
Commencement Date	1st October 2006
Entry Point	The point of redelivery of Barrel field fluids into the SEGAL system
Redelivery Point (s)	NTS at St. Fergus and Braefoot bay jetties
Capacity/variation rights (Y/N) and timing (refer to Note 3)	30mmscf/d for 3 yrs., variation possible post 2010
Send or Pay/carry forward provisions (yes/no)/Duration	100%, no carry forward provisions
Priority rights during periods when service provision is reduced	Equal priority with other users
Technical Requirements (refer to Note 4)	
Payment Structure (refer to Note 5)	
Tariff range for service provided (refer to Note 6)	20 to 23 pence per kscf for gas and £30 to £35 per tonne of NGLs No indexation
Range of any separate contribution to capex and opex	None
Any other payment(s) with range and timing (refer to Note 7)	Opex sharing provision post 2010 Reward element includes ethane taken as fee in kind
L&I/Risk Regime fundamentals	
Important Additional Data (refer to Note 8) <i>Fiscal metering required on Wine platform</i>	

Notes

- (1) Include key provisions and services that have a material impact on risk-reward.
- (2) Include any important and unusual elements that materially impact risk-reward.
- (3) For each main stream e.g. oil, gas etc.
- (4) Should include relevant entry specifications and any important and unusual technical issues.
- (5) The ranges should reflect the type of service provided (price range should be within a 15% band).
- (6) Include summary of indexation principles with floors and ceilings.
- (7) Include any fee in kind type payments relating to single component streams, or production deferral in a CTA.
- (8) Include any key provisions that materially impact risk-reward not mentioned above (e.g. hydrocarbon accounting, risk, property, title, extension of terms, assignment (incl. limitations), security provisions, metering, termination, ownership and decommissioning in a CTA etc).

Disclaimer

The summary information provided above is provided by [OwnerOilCo] as the service provider:

- (1) In good faith and without any liability.
- (2) Without warranty, implied or express as to its accuracy or relevance of use by any other party.
- (3) Without obligation to provide any further information in respect of the agreement/transaction to which the summary relates.
- (4) Without any obligation to provide access to infrastructure or services on the same terms and conditions.

F.1.5 Infrastructure Access Agreement Summary 1

This data is provided in accordance with the disclaimer conditions noted below:

Provided in relation to the voluntary Industry Infrastructure Code of Practice. To be used in summarising construction and tie-in and transportation and processing agreements by the owner/operator for inclusion in the publication of key commercial terms (refer to Paragraph 13 (1)).	Ref: TPOSA ISCCA 000003
Agreement Title and Date: <i>Agreement for the Transportation Processing and Operational Services Agreement for the Wine field fluids over the Barrel Platform dated 7th February 2004</i>	
Scope of agreement/responsibilities: (refer to Note 1) <i>The Wine field owners shall deliver the Wine field fluids to the base of the Barrel platform riser. [OwnerOilCo] as Barrel field operator shall provide the following main services (on behalf of owners): Accept and process all Wine field fluids within spec Redeliver Wine field oil to the base of the oil riser into the Forties system Redeliver Wine field gas to the base of the gas riser to the SEGAL system Provide chemical injection services as specified Provide system metering, control, shutdown and telemetry services as specified</i>	
Key Provisions (refer to Note 2)	
Commencement Date	<i>1st October 2006</i>
Entry Point	<i>Base of the Spare Barrel riser</i>
Redelivery Point(s)	<i>Base of existing oil and gas risers</i>
Capacity/variation rights (Y/N) and timing (refer to Note 3)	<i>Gross fluids 10,000b/d plateau for 3 years</i>
Send or Pay/carry forward provisions (yes/no)/Duration	<i>100% no variation rights</i>
Priority rights during periods when service provision is reduced	<i>Equal to other Barrel platform users</i>
Technical Requirements (refer to Note 4)	
Payment Structure (refer to Note 5)	
Tariff range for service provided (refer to Note 6)	<i>£1.30 to £1.50 per barrel of gross fluids processed, indexed 100% to PPI</i>
Range of any separate contribution to capex and opex	<i>None</i>
Any other payment(s) with range and timing (refer to Note 7)	<i>Opex sharing provision post 2010</i>
L&I/Risk Regime fundamentals	
Important Additional Data (refer to Note 8) <i>Any pigging operations to be charged at cost Commissioning gas to be charged in range 20 to 23 pence per therm.</i>	

Notes

- (1) Include key provisions and services that have a material impact on risk-reward.
- (2) Include any important and unusual elements that materially impact risk-reward.
- (3) For each main stream e.g. oil, gas etc.
- (4) Should include relevant entry specifications and any important and unusual technical issues.
- (5) The ranges should reflect the type of service provided (price range should be within a 15% band).
- (6) Include summary of indexation principles with floors and ceilings.
- (7) Include any fee in kind type payments relating to single component streams, or production deferral in a CTA.
- (8) Include any key provisions that materially impact risk-reward not mentioned above (e.g. hydrocarbon accounting, risk, property, title, extension of terms, assignment (incl. limitations), security provisions, metering, termination, ownership and decommissioning in a CTA etc).

Disclaimer

The summary information provided above is provided by [OwnerOilCo] as the service provider:

- (1) In good faith and without any liability.
- (2) Without warranty, implied or express as to its accuracy or relevance of use by any other party.
- (3) Without obligation to provide any further information in respect of the agreement/transaction to which the summary information relates.
- (4) Without any obligation to provide access to infrastructure or services on the same terms and conditions

F.1.6 Infrastructure Access Agreement Summary 2

This data is provided in accordance with the disclaimer conditions noted below:

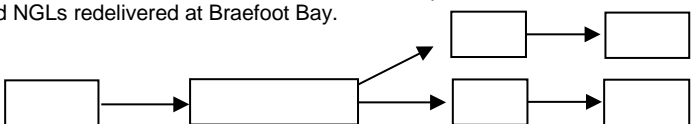
Ref: Wine Field Summary	Provided in relation to the voluntary Industry Infrastructure Code of Practice. To be used in summarising construction and tie-in and transportation and processing agreements by the owner/operator for inclusion in the publication of key commercial terms (refer to Paragraph 13 (1)).
Infrastructure Access Summary for:	<i>Wine Field Development</i>
Field Development: Single subsea oil producing well tie-back to host platform. Host Operator provides separation and control (TPOSA) services. Crude Oil transported to shore via Forties system and redelivered at Hound Point: Wet Gas transported via the SEGAL, with sales gas redelivered into the NTS at St Fergus and NGLs redelivered at Braefoot Bay.	
	
Suite of Main Agreements (refer to Note 1)	
Ref:	<i>Commercial Arrangement/Agreement Title</i>
ISCCA 000001	<i>Agreement for the Construction and Tie-in of the Wine field to the Barrel platform dated 7th February 2004</i>
ISCCA 000002	<i>Agreement for the Transportation, Processing and Operational Services agreement for the Wine field fluids over the Barrel platform dated 7th February dated 7th February 2004</i>
ISCCA 000003	<i>Agreement for the Transportation and Processing of Wine field gas through the SEGAL system dated 7th February 2004</i>
ISCCA 000004	<i>Agreement for the Transportation and Processing of Wine field oil through the Forties system dated 7th February 2004</i>

Field Details:	
Field Name	<i>Wine field</i>
Licence	<i>P.344</i>
Block Number	<i>16/21c</i>
Operator	<i>UserOilCo</i>
Partners	<i>PartnerOilCo</i>

Field Streams/Characteristic:					
Stream	Crude oil				Gas
Relevant (Y/N)	Y	Y	Condensate	NGLs	Produced Water
Unique characteristics (refer to Note 2)					Y
Reserves	<i>2 to 3MMB</i>	<i>1BCF</i>			<i>Produced water production ramps up significantly after 3 years</i>
Initial Rate	<i>12,000BOPD</i>	<i>30MMscf/d</i>			
Plateau	<i>3 years</i>	<i>3 years</i>	<i>0BOPD</i>	<i>0BOPD</i>	<i>0BWPD</i>
Plateau/Peak production	<i>12,000BOPD</i>	<i>30MMscf/d</i>			

Notes

- (1) Other agreements may exist e.g. pipeline crossings, confidentiality, but they do not materially impact risk-reward.
- (2) For example – low API, high H₂S, High CO₂, significant sand production etc.

Disclaimer

The summary information above is provided by [UserOilCo] as [Wine] field Operator:

- (1) In good faith and without any liability.
- (2) Without warranty, implied or express as to its accuracy or relevance of use by any other party.
- (3) Without obligation to provide any further information in respect of the agreement/transaction to which the summary information relates.
- (4) Without any obligation to provide access to infrastructure or services on the same terms and conditions.

OIL & GAS UK



Oil & Gas
Authority



London Office:
6th Floor East, Portland House, Bressenden Place, London, SW1E 5BH
Tel: 020 7802 2400 Fax: 020 7802 2401

Aberdeen Office:
Exchange 2, 3rd Floor, 62 Market Street, Aberdeen, AB11 5PJ
Tel: 01224 577250 Fax: 01224 577251

info@oilandgasuk.co.uk
www.oilandgasuk.co.uk

ISBN: 1 903 004 84 5
Copyright © 2017 The UK Oil and Gas Industry Association Limited trading as Oil & Gas UK

